

**XINO**  
maximum innovation

*workaholic*

S700  
High-performance scanning system

**S700** High-performance scanning system



**FLEXIBILITY  
PRODUCTIVITY  
PROFITABILITY**

# PERFECTION AND PERFORMANCE.

The XINO S700 high-performance scanning system from microform.

Sophisticated digitization solutions in particular require high-performance scanning systems that meet the wide range of demands with respect to quality and quantity of documents – and will continue to do so long term, too. The new XINO S700 high-performance scanning system from microform is a real trend-setter. The multi-stream system generates color, grayscale and black-and-white images as required. It features top-level productivity, while offering great versatility and excellent economy. All components integrated

are designed for longevity and ensure perfect document handling reliability in day-to-day production – if needs be, 24 hours a day, 7 days a week. Great importance has been attached to achieving balanced ergonomics for the entire system, so that it enjoys a high level of acceptance from its users. The open concept of the system ensures it is efficient to work with in a wide variety of application environments.

The Best Image Quality concept stands not only for perfect scanning quality but for high-performance scanning technology and progressive imaging functions, too.



## 01 100% ERGONOMIC.

Flexible workstation layout optimizes productivity.

Productivity, performance and ergonomics take absolute priority for the entire XINO S700 system. The sophisticated workstation concept is highly production-oriented and makes the system exceedingly easy to use thanks to the motorized height adjustment feature. This makes the system a joy to work with and ensures productivity is high.

### Flexible workplace layout

The carefully designed workplace concept incorporates motorized height adjustment for the entire system and also the ability to

adjust the positions of the work surfaces attached either side to the users' needs, so they can work as efficiently and productively as possible.

### Optimized sheet separation

The XINO S700 scanning system is equipped as standard with a totally new batch feeder. The maximum document batch height is 500 sheets. Thanks to the integral memory function, the system adapts automatically to smaller document batch

heights. And of course, single-sheet feeding is also possible. What's more, the operator can even change the entire feeder system if necessary. The easy-change roller system enables the operator to change the friction rollers effortlessly if necessary.

### Perfected ultrasonic system

The integral ultrasonic double-sheet detection facility consists of three independently controlled sensors that cover almost the entire width of the documents. As a result, the system is capable of handling all sorts of documents efficiently.

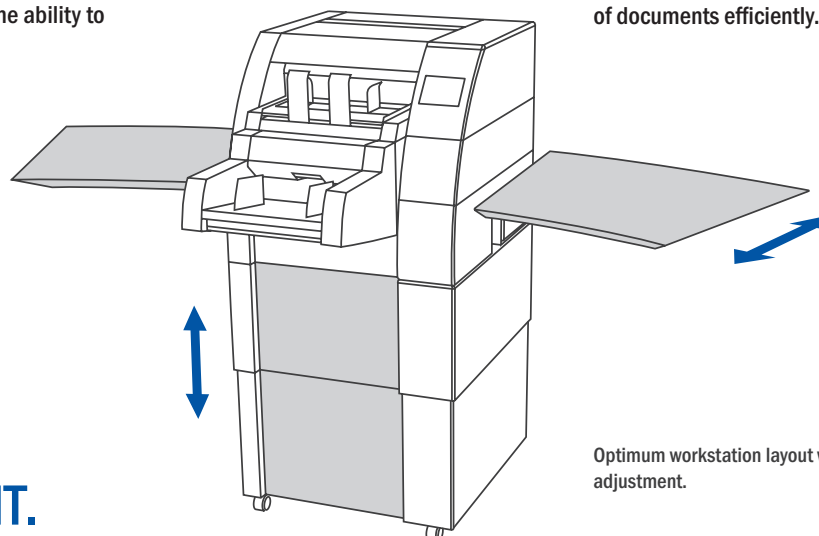

Optimum workstation layout with motorized height adjustment.

## 02 BRILLIANT.

The perfect lens system.

The camera has been completely new designed and is available with two resolutions: 400 dpi or 600 dpi. The entire optical system is encased to keep out dust and make

the system exceedingly low-maintenance. The LED lighting – which is also new – provides optimum support for the scanning process, guaranteeing Best Image Quality and

a long service life from the scanner thanks to uniform illumination.

## 03 USER-FRIENDLY.

The new color touch-sensitive control panel.

### Comfort, convenience and efficiency

The new color touch-sensitive control panel of the XINO S700 system makes sure that communication between human and machine is clear-cut and unambiguous. All functions are easy to understand and clearly displayed on the system's display. Handling is simple and user-friendly. What's more, the human-machine interface (HMI) can be adapted to the particular task at hand, with the menus and command sequences being able to be configured to a customer's own requirements – if necessary, even job-specific or in line with users' qualifications and capabilities. The complete process installed in the system is menu-driven and intuitive. Basic scanning functions (Start, Stop, Pause, etc.) can be executed directly on the machine without having to use a PC keyboard.

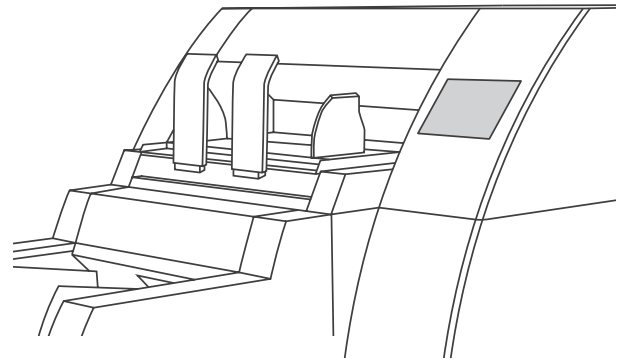

## 04 SAFETY FIRST.

Reliable and gentle document processing.

The unique paper transport system of the XINO S700 scanner series offers maximum possible flexibility with respect to the paper grades and weights it is capable of handling. The roller-ball system handles virtually all types of document, with paper grades ranging from air-

mail paper to thick board, including of course documents with additional information stuck. The tolerant paper deflection mechanism ensures maximum process reliability.

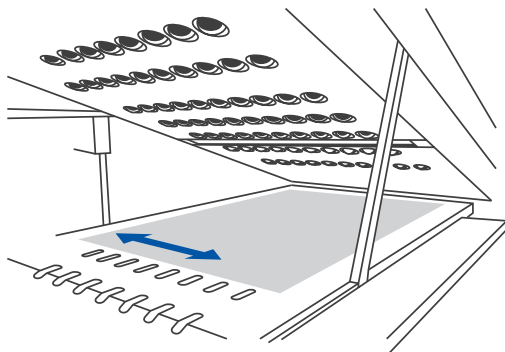

315 mm transport width

180° paper deflection

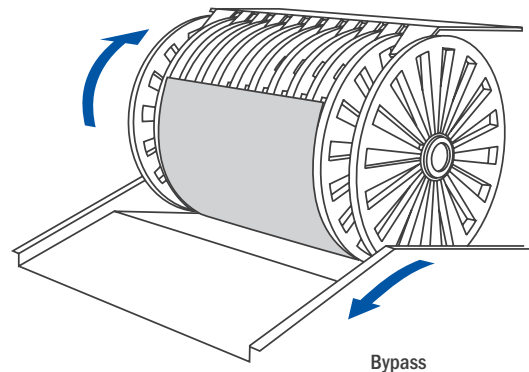

## 05 UNIQUE.

Bypass and Patchcode Sorter.

The system is equipped with a switchable paper transport system with document delivery either at the front in easy reach of the operator or at the back of the unit. Straight-through document feed with delivery at the rear of the system saves rerouting the sheet and eliminates any risk of damage when handling flimsy documents for instance. Together with the optional Patchcode Sorter, this version allows patchcode sheets to be automatically identified, fed through the bypass of the scanner and ejected.

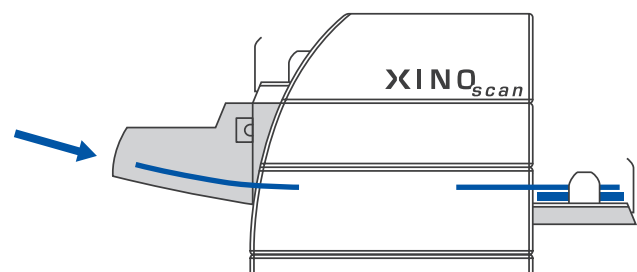

Patchcode Sorter  
Variable paper output with sorter function

**02** OPTICS AND LIGHT

**01** 100% ERGONOMIC

**05** BYPASS



**03** TOUCH CONTROL PANEL

**04** PAPER TRANSPORT

**S700** High-performance scanning system

# INNOVATION BY EXPERIENCE.

For productive and economic document capturing processes.

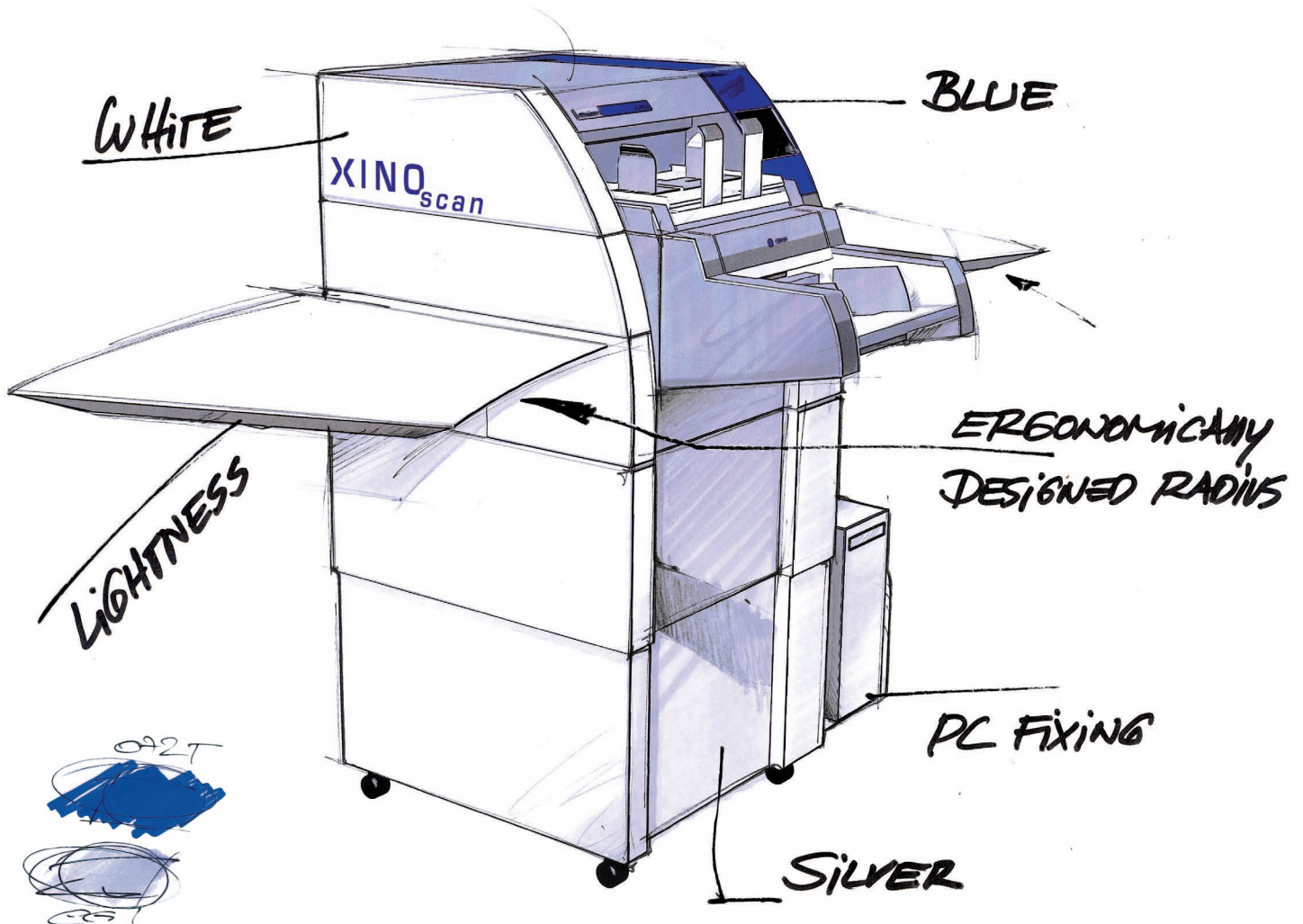

The constant exchange of information between users and the manufacturer form the perfect basis on which to develop new, 100% market-oriented systems. And the new XINO S700 scanner system from microform is perfectly oriented to the needs and wishes of the market. The concept of the entire system, in conjunction with the easy-to-use human-machine interface and possibilities for integra-

tion, form the basis for reliable and efficient processing of all sorts of documents on varying paper grades. The XINO S700 system fulfills a massive range of requirements, irrespective of whether you are dealing with demanding incoming-mail solutions for paperless processing of documents or the archiving of document processes already completed.

## XINOCapture software

In addition to the hardware, a powerful scanning solution requires software tailored to the specific production requirements. microform's "XINOCapture" software meets these requirements in all respects. It is available in a number of modular levels and a wide range of plug-ins can be added to enhance its functionality. It features batch-oriented processes, professional image editing and standardized user dialogs. The Standard version of XINOCapture included in the scope of delivery of

the XINO S700 system already incorporates a multitude of application-oriented functions. Apart from scan job design, these include a range of image processing functions, the execution of event rules, and the processing of different barcodes. Users can benefit from a range of additional powerful functions by upgrading to the XINOCapture Professional or XINOCapture Gold version.

## Technical data

<b>Camera</b>	2 x Trilinear CCD camera in dust-protected casing	<b>Document format</b>	Minimum 60 x 100 mm Maximum 315 x 4000 mm
<b>Lighting</b>	LED light unit	<b>Paper weight</b>	40 - 250 g/m <sup>2</sup>
<b>Resolution</b>	400 dpi optical 600 dpi optical optional	<b>Paper feed</b>	Batch feeder for max. 500 sheets Automatic memory function for document batch height Ultrasonic double-sheet detector with 3 separately controllable sensors Easy-change roller system
<b>Output resolution</b>	75, 100, 150, 200, 300, 400 dpi, 600 dpi optional	<b>Paper-run monitoring</b>	by means of LEDs
<b>Image output</b>	24-bit True Color, 8-bit grayscale, 1-bit bitonal	<b>Paper transport system</b>	with optional straight-through feed with delivery at the rear of the system (bypass) or 180° deflection to the front of the system
<b>Imaging functions</b>	Best Image Quality for <ul style="list-style-type: none"> <li>• dual- or multistream scanning</li> <li>• MDIT - Multi Dimensional Intelligent Thresholding</li> <li>• Deskew, cropping, despec</li> <li>• RSOD - Rescan on Demand</li> <li>• Digital color filtering</li> <li>• Gamma correction</li> <li>• Smart Color Detection</li> </ul>	<b>Human-machine interface (HMI)</b>	Color, touch-sensitive control panel
<b>Image output</b>	TIFF, JPG, PDF compressed or noncompressed	<b>Document printing</b>	Imprinter for printing front of documents Endorser for printing rear of documents fitted as standard
<b>Interfaces</b>	SCSI-3, USB 2.0	<b>System Control</b>	XINOCapture Standard software included in scope of delivery Upgrade possible to XINOCapture Professional XINOCapture Gold
<b>Drivers</b>	TWAIN, ISIS (in preparation)	<b>Options</b>	Ergonomic XINO S700 workstation Real-time patchcode reader Patchcode sorter
<b>Scanning speed at 200 dpi</b>	XINO S713 Up to 130 ppm for A4 Landscape XINO S716 Up to 160 ppm for A4 Landscape XINO S720 Up to 200 ppm for A4 Landscape Systems upgradable		

\* subject to change without prior notice.